

REV.	ECN NO. / DESCRIPTION	DATE
1	N030263	10/17'03
2	N040207	05/21'04
3	N070146	04/26'07

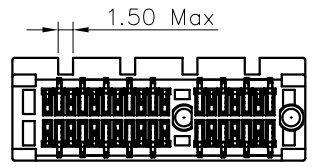
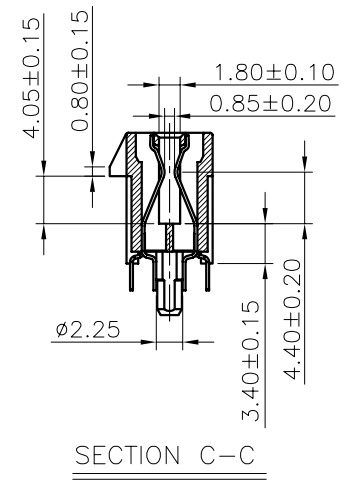
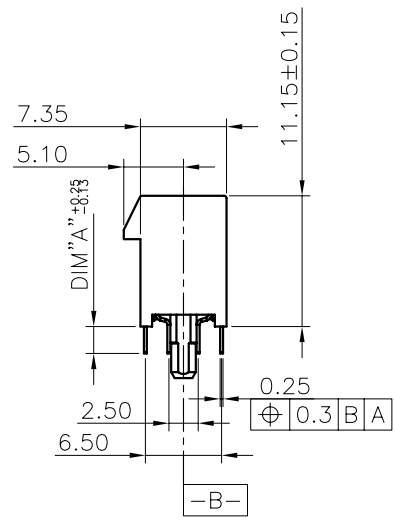
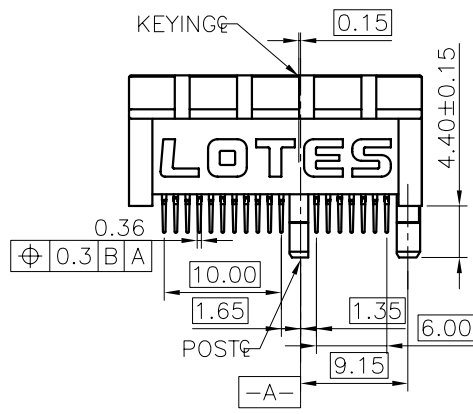
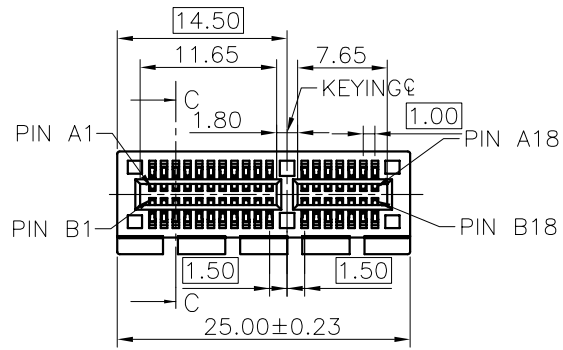

ITEM	COMPONENT	QUANTITY	MATERIAL	FINISH	DIM "A"
2	TERMINAL	36	PHOSPHOR BRONZE OR BRASS	GOLD PLATING ON CONTACT AREA OPTIONAL OF 1U", 15U" OR 30U"	OPTIONAL: 2.30mm OR 2.54mm OR 3.10mm
1	HOUSING	1	OPTIONAL: PA46, PA66 OR EQUIVALENT	COLOR: OPTIONAL BLACK, BLUE 287C, GREEN 353U OR EQUIVALENT	

GENERAL TOLERANCES UNLESS SPECIFIED		PART NO. AAA-PCI-003-***	LOTES		
X ± 0.35	X° ± 2.5°				
.XX ± 0.20	X° ± 1.5°	APPROVED BY SMARK 4/26'07	TITLE 36PIN PCI-EXPRESS CONNECTOR		
.XXX ± 0.15	.XX° ± 1.0°	CHECKED BY JOE 4/26'07	DWG NO. GAP-AAA-PCI-003		
CUSTOMER DRAWING		DRAWN BY LEI 4/26'07	SHEET 1 / 4	SCALE 3:2	REV 3
SIZE A4	UNITS MM [INCH]				

F

E

D

C

B

A

F

E

D

C

B

A

1 2 3 4 5 6 7 8

1 2 3 4 5 6 7 8

REV.	ECN NO. / DESCRIPTION	DATE
1	N030263	10/17'03
2	N040207	05/21'04
3	N070146	04/26'07

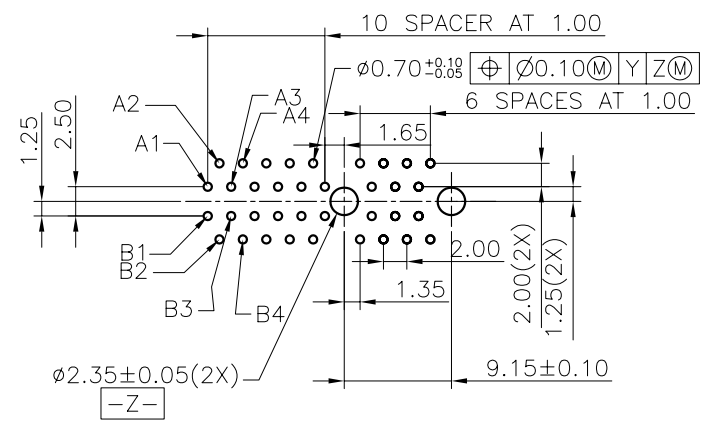
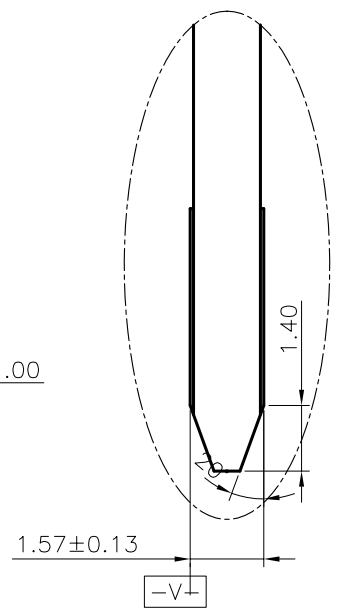
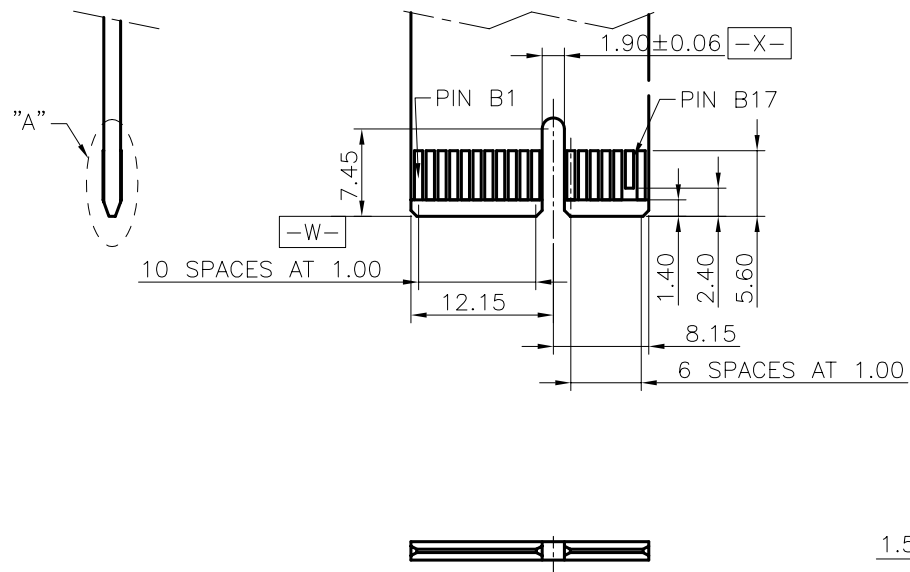

RECOMMENDED FOOTPRINT(TOP VIEW)
DEFAULT TOLERANCE ±0.05

DETAIL "A"
SCALE 4/1

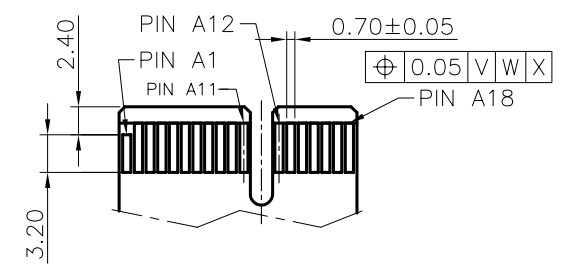

ADD-IN CARD EDGE-FINGER DIMENSIONS
DEFAULT TOLERANCE ±0.05

GENERAL TOLERANCES UNLESS SPECIFIED		PART NO.	LOTES		
X ± 0.35	X° ± 2.5°	AAA-PCI-003-***			
.XX ± 0.20	.X° ± 1.5°	APPROVED BY	TITLE		
.XXX ± 0.15	.XX° ± 1.0°	SMARK 04/26'07	36PIN PCI-EXPRESS CONNECTOR		
CUSTOMER DRAWING		CHECKED BY	DWG NO.		
		JOE 04/26'07	GAP-AAA-PCI-003		
SIZE	UNITS	DRAWN BY	SHEET	SCALE	REV
A4	MM[INCH]	LEI 04/26'07			

REV.	ECN NO. / DESCRIPTION	DATE
1	N030263	10/17'03
2	N040207	05/21'04
3	N070146	04/26'07

PART NUMBER	SPECIFICATION	TAIL L
AAA-PCI-003-001	PA46_BLACK; PHOSPHOR BRONZE_15u"; POST;L.T	2.30mm
AAA-PCI-003-002	PA46_BLACK; PHOSPHOR BRONZE_GOLD FLASH; POST; L.T	2.30mm
AAA-PCI-003-003	PA46_WHITE; PHOSPHOR BRONZE_GOLD FLASH; POST; L.T	2.30mm
AAA-PCI-003-004	PA46_WHITE; PHOSPHOR BRONZE_GOLD 15u"; POST; L.T	2.30mm
AAA-PCI-003-005	PA46_BLACK; PHOSPHOR BRONZE_GOLD 15u"; POST; L.T;	3.10mm
AAA-PCI-003-006	PA46_WHITE; PHOSPHOR BRONZE_GOLD 15u"; POST; L.T	3.10mm
AAA-PCI-003-007	PA66_BLACK; PHOSPHOR BRONZE_GOLD FLASH; POST; L.T	2.30mm
AAA-PCI-003-008	PA66_BLU287C; PHOSPHOR BRONZE_GOLD FLASH; POST; L.T	2.30mm
AAA-PCI-003-009	PA66_GREEN353U; PHOSPHOR BRONZE_GOLD FLASH; POST; L.T	2.30mm
AAA-PCI-003-010	PA66_RED395C; PHOSPHOR BRONZE_GOLD FLASH; POST; L.T	2.30mm
AAA-PCI-003-011	PA66_YELLOW122U; PHOSPHOR BRONZE_GOLD FLASH; POST; L.T	2.30mm
AAA-PCI-003-012	PA66_YELLOW395C; PHOSPHOR BRONZE_GOLD FLASH; POST; L.T	2.30mm
AAA-PCI-003-013	PA66_RED212C; PHOSPHOR BRONZE_GOLD FLASH; POST; L.T	2.30mm
AAA-PCI-003-014	PA66_BLACK; PHOSPHOR BRONZE_GOLD 15u"; POST; L.T	2.30mm
AAA-PCI-003-015	PA66_Warm red U; PHOSPHOR BRONZE_GOLD FLASH; POST; L.T	2.30mm
AAA-PCI-003-016	PA66_WHITE; PHOSPHOR BRONZE_GOLD FLASH; POST; L.T	2.30mm
AAA-PCI-003-017	PA66_YELLOW803C; PHOSPHOR BRONZE_GOLD FLASH; POST; L.T	2.30mm
AAA-PCI-003-G01	PA46_BLACK; PHOSPHOR BRONZE_15u"; POST; L.T, LEAD FREE	2.30mm
AAA-PCI-003-K01	PA46_BLACK; PHOSPHOR BRONZE_15u"; POST; L.T, LEAD FREE	2.30mm
AAA-PCI-003-K01_A	PA46_BLACK; PHOSPHOR BRONZE_15u"; POST; L.T, LEAD FREE	2.30mm
AAA-PCI-003-F01	PA46_BLACK; PHOSPHOR BRONZE_15u"; POST; L.T, LEAD FREE	2.30mm
AAA-PCI-003-K02	PA46_BLACK; PHOSPHOR BRONZE_GOLD FLASH"; POST; L.T, LEAD FREE	2.30mm
AAA-PCI-003-N02	PA46_BLACK; PHOSPHOR BRONZE_GOLD FLASH"; POST; L.T, LEAD FREE	2.30mm

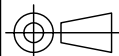
GENERAL TOLERANCES UNLESS SPECIFIED		PART NO. AAA-PCI-003-***	LOTES			
.X ±0.35	X° ±2.5°					
.XX ±0.20	X° ±1.5°	APPROVED BY SMARK 04/26'07	TITLE 36PIN PCI-EXPRESS CONNECTOR			
.XXX ±0.15	.XX° ±1.0°	CHECKED BY JOE 04/26'07	DWG NO. GAP-AAA-PCI-003			
CUSTOMER DRAWING		DRAWN BY LEI 04/26'07		SHEET	SCALE	REV
SIZE A4	UNITS MM[INCH]			3 / 4	3:2	3

REV.	ECN NO. / DESCRIPTION	DATE
1	N030263	10/17'03
2	N040207	05/21'04
3	N070146	04/26'07

PART NUMBER	SPECIFICATION	TAIL L
AAA-PCI-003-K04	PA46_WHITE; PHOSPHOR BRONZE_15u"; POST;LT	2.30mm
AAA-PCI-003-K05	PA46_BLACK; PHOSPHOR BRONZE_15u"; POST; L.T	3.10mm
AAA-PCI-003-K05_A	PA46_WHITE; PHOSPHOR BRONZE_15u"; POST; L.T	3.10mm
AAA-PCI-003-K16	PA46_WHITE; PHOSPHOR BRONZE_GOLD FLASH; POST; L.T;	2.30mm
AAA-PCI-003-K16_A	PA46_WHITE; PHOSPHOR BRONZE_GOLD FLASH; POST; L.T;	2.30mm
AAA-PCI-003-K17	PA46_YELLOW803C; PHOSPHOR BRONZE_GOLD FLASH; POST; L.T	2.30mm
AAA-PCI-003-K19	PA46_GREEN353U; PHOSPHOR BRONZE_GOLD FLASH; POST; L.T	2.30mm
AAA-PCI-003-K21	PA46_BLACK; PHOSPHOR BRONZE_GOLD FLASH; POST; L.T, LEAD FREE	2.30mm
AAA-PCI-003-K21_A	PA46_BLACK; PHOSPHOR BRONZE_GOLD FLASH; POST; L.T, LEAD FREE	2.30mm
AAA-PCI-003-K22	PA46_BLACK; PHOSPHOR BRONZE_GOLD FLASH; POST; L.T, LEAD FREE	3.10mm
AAA-PCI-003-K26	PA46_BLACK; PHOSPHOR BRONZE_30u"; POST; L.T	3.10mm
AAA-PCI-003-K30	PA46_BLACK; PHOSPHOR BRONZE_GOLD FLASH; POST; L.T	2.54mm
AAA-PCI-003-F41	PA46_BLACK; PHOSPHOR BRONZE_10U"; POST; L.T	2.30mm
AAA-PCI-003-K42	PA46_BLACK; PHOSPHOR BRONZE_15U"; POST; L.T	2.54mm
AAA-PCI-003-K44	PA46_WHITE; PHOSPHOR BRONZE_G/F; POST; L.T	2.54mm
AAA-PCI-003-P43	HTN_BLACK; PHOSPHOR BRONZE_G/F; POST; L.T,HF	2.30mm
AAA-PCI-003-K45	PA46_WHITE; PHOSPHOR BRONZE_15u"; POST; L.T	3.10mm

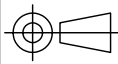
GENERAL TOLERANCES UNLESS SPECIFIED		PART NO. AAA-PCI-003-***	LOTES			
.X ±0.35	X° ±2.5°					
.XX ±0.20	X° ±1.5°	APPROVED BY SMARK 04/26'07	TITLE 36PIN PCI-EXPRESS CONNECTOR			
.XXX ±0.15	.XX° ±1.0°	CHECKED BY JOE 04/26'07	DWG NO. GAP-AAA-PCI-003			
CUSTOMER DRAWING		DRAWN BY LEI 04/26'07		SHEET 4 / 4	SCALE 3:2	REV 3
SIZE A4	UNITS MM[INCH]					