

| REV. | ECN NO./DESCRIPTION | DATE |
|------|---------------------|----------|
| A | R110782 | 01/03'12 |
| B | R110782 | 06/05'12 |
| C | R110782 | 07/22'12 |

NOTES:

- MATERIAL: HOUSING: PA66+30%GF Or PA46 40%GF(SEE TABLE), UL94V-0, COLOR: BLACK.
EJECTOR: PA66+30%GF, UL94V-0, COLOR: WHITE.
CONTACT: PHOSPHOR BRONZE.
HOOK: STELL ALLOY.
- FINISH: CONTACT: 50u"MIN NICKEL UNDERPLATED; GOLD PLATED ON CONTACT AREA.(SEE TABLE)
100u"MIN MATTE TIN PLATED ON SOLDER AREA.
HOOK:100u"MIN MATTE TIN PLATED ON SOLDER AREA.
- RECOMMENDED MODULE LAYOUT SHOULD BE MO-XXX FROM JEDEC.
- WAVE SODERING TEMPRATURE:
THE CONNECTOR SHALL BE MOUNTED ON THE PCB;THE TEMPERATURE OF THE SOLDER SHALL BE 260±5°C AND IMMERSION DURATION:10±1 SECONDS.
- RoHS AND HF COMPLIANT.

| GENERAL TOLERANCES UNLESS SPECIFIED | | PART NO. | | LOTES | | |
|-------------------------------------|-------------------|-----------------------------------|--|-------------------------|--|--|
| .X± 0.35 | X°± 3° | SEE TABLE | | | | |
| .XX± 0.25 | .X°± 2° | APPROVED BY DeFang_Hu 07/22'12 | | DWG NO. GAP-ADDR0005 | | |
| .XXX± 0.15 | .XX°± 1° | CHECKED BY JinKe_Hu 07/22'12 | | | | |
| CUSTOMER DRAWING | | DRAWN BY ZhenFeng_Lv 07/22'12 | | SCALE 5:4 | | |
| SIZE A4 | UNITS MM[INCH] | | | REV C | | |

| REV. | ECN NO./DESCRIPTION | DATE |
|------|---------------------|----------|
| A | R110782 | 01/03'12 |
| B | R110782 | 06/05'12 |
| C | R110782 | 07/22'12 |

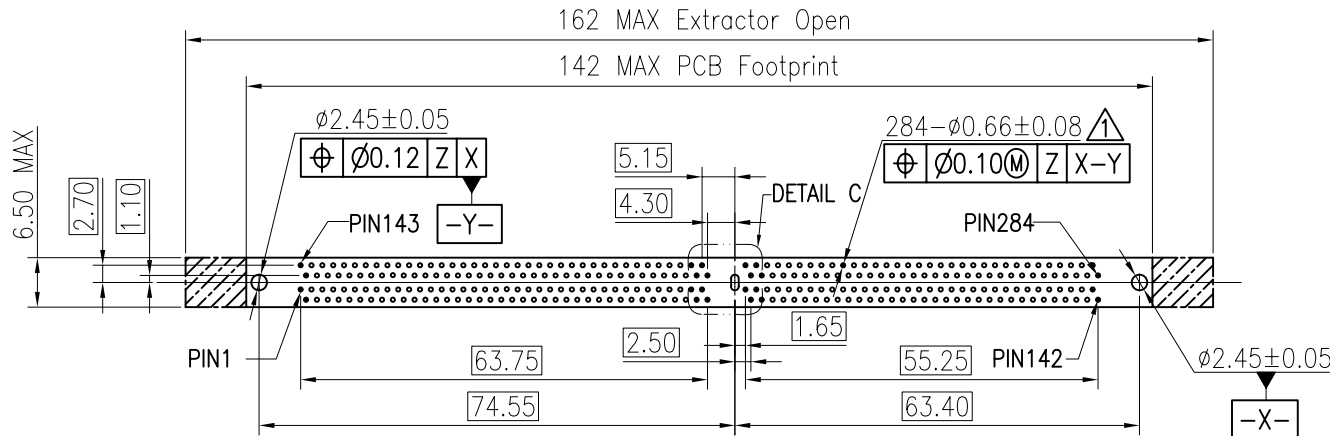

RECOMMENDED PCB LAYOUT(CONNECTOR SIDE) (TOL.:±0.05)

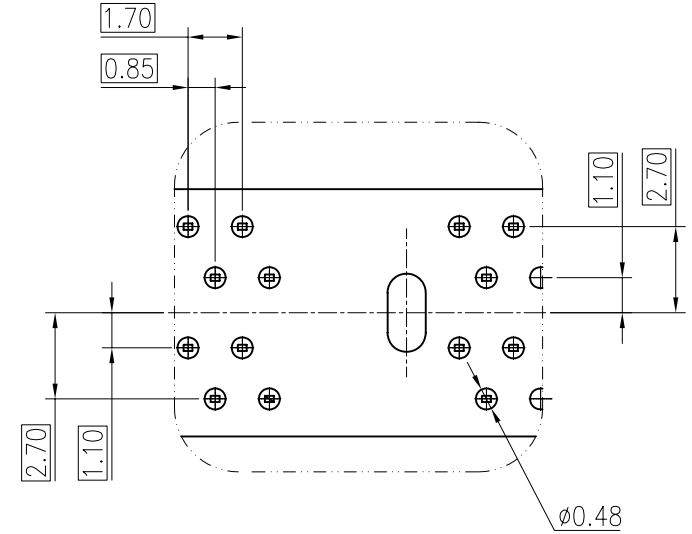

OUTER LOCUS OF CONNECTOR SOLDER PIN TAILS
SCALE 5:1

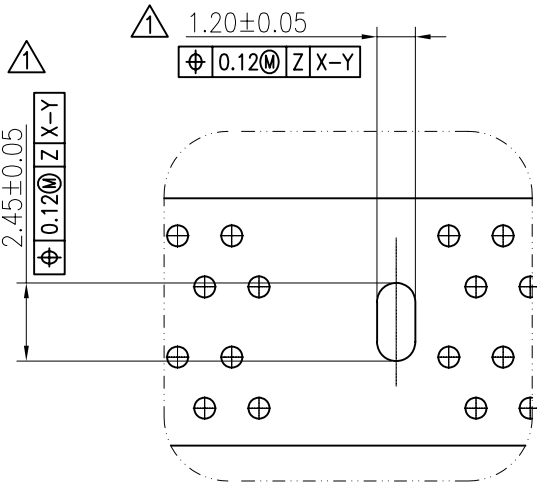

DETAIL C
SCALE 5:1

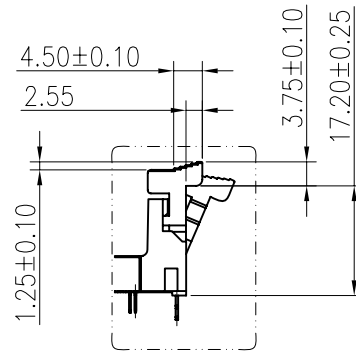

DETAIL B
SCALE 1:1

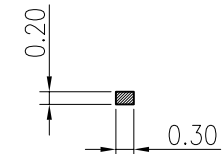

SOLDER TAIL SECTION
SECTION B-B(10:1)

RECOMMENDED DIMENSIONS OF THESE FEATURES WERE DERIVED TO ALLOW A ROUTING SOLUTION ON THE MOTHERBOARD.

| GENERAL TOLERANCES UNLESS SPECIFIED | | PART NO. | | LOTES | | |
|-------------------------------------|-----------|----------------------|--|-------------------|-------|-----|
| .X ± 0.35 | X° ± 3° | SEE TABLE | | | | |
| .XX ± 0.25 | .X° ± 2° | APPROVED BY | | DDR4 284Pin Conn. | | |
| .XXX ± 0.15 | .XX° ± 1° | DeFang_Hu 07/22'12 | | DWG NO. | | |
| CUSTOMER DRAWING | | CHECKED BY | | GAP-ADDR0005 | | |
| | | JinKe_Hu 07/22'12 | | | | |
| SIZE | UNITS | DRAWN BY | | SHEET | SCALE | REV |
| A4 | MM[INCH] | ZhenFeng_Lv 07/22'12 | | 2 / 4 | 5:4 | C |

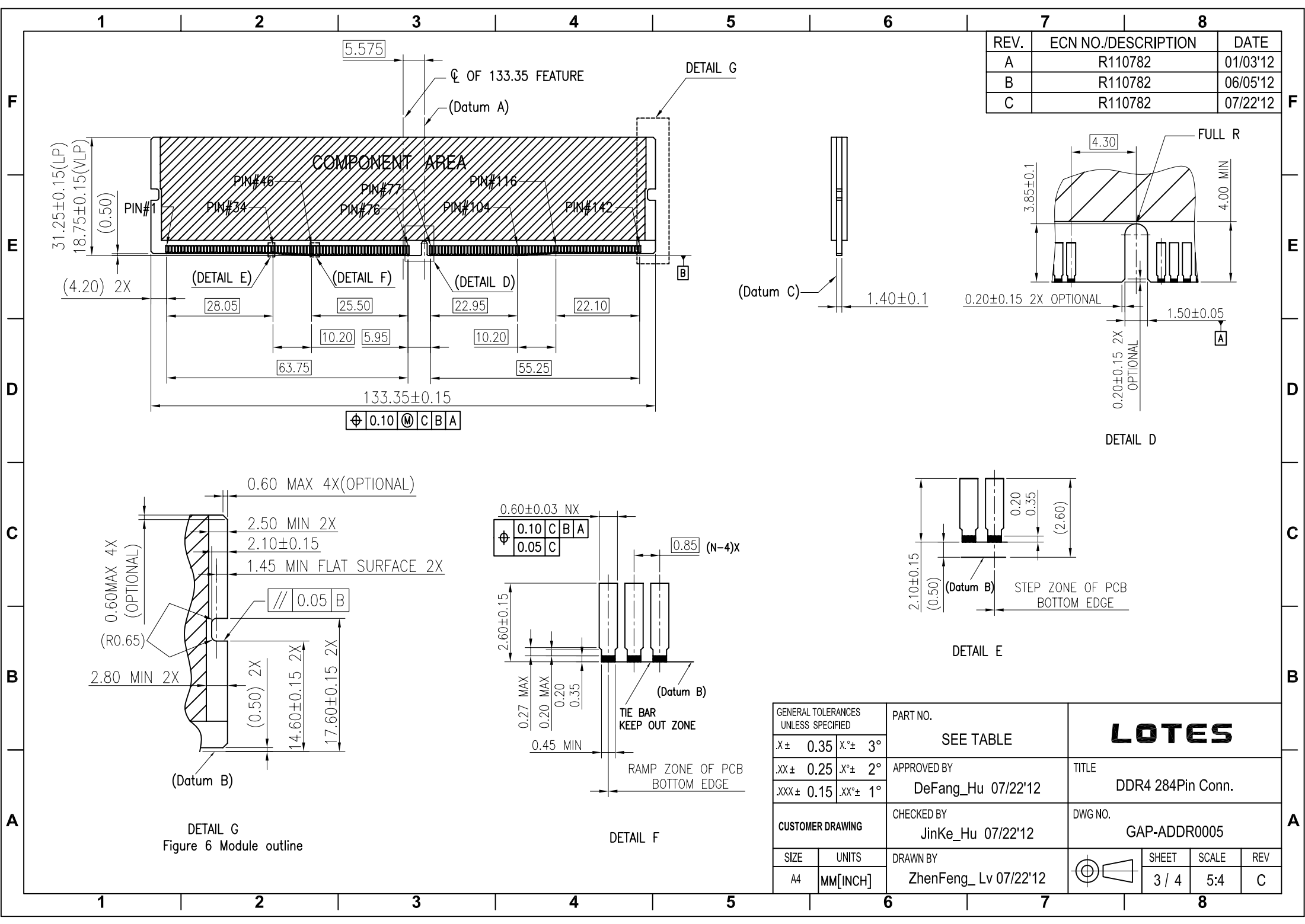

| REV. | ECN NO./DESCRIPTION | DATE |
|------|---------------------|----------|
| A | R110782 | 01/03'12 |
| B | R110782 | 06/05'12 |
| C | R110782 | 07/22'12 |

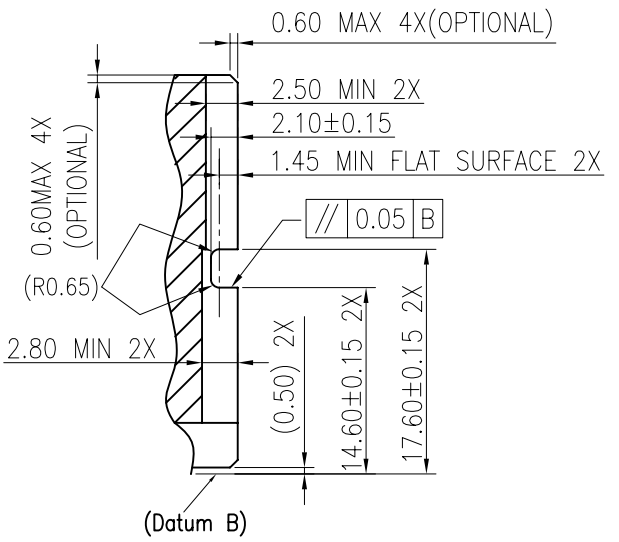
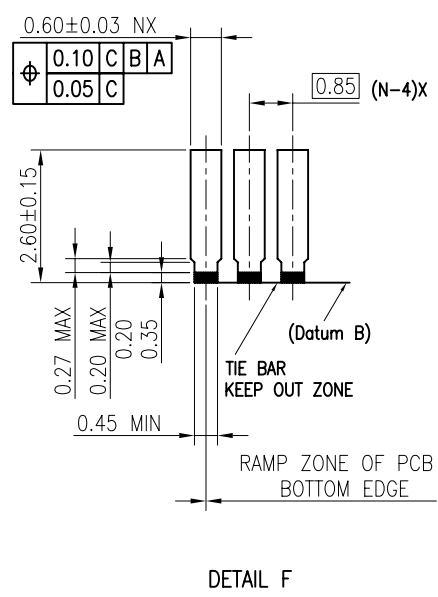
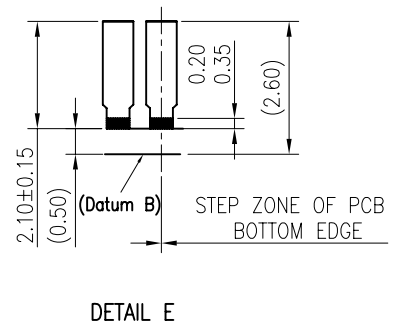
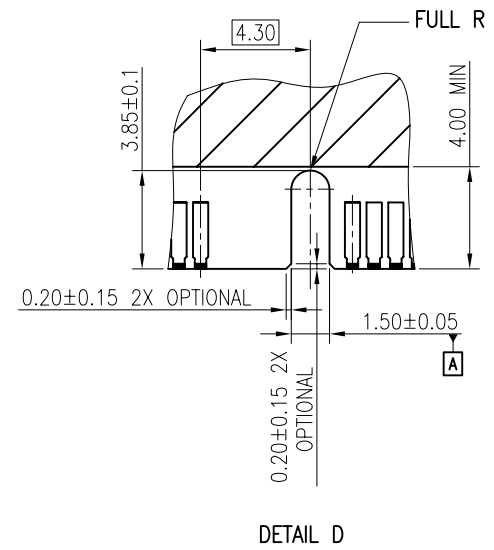

| GENERAL TOLERANCES UNLESS SPECIFIED | | PART NO. | | LOTES | | |
|-------------------------------------|-----------|----------------------|--|-------------------|-------|--|
| .X ± 0.35 | X° ± 3° | SEE TABLE | | | | |
| .XX ± 0.25 | .X° ± 2° | APPROVED BY | | DDR4 284Pin Conn. | | |
| .XXX ± 0.15 | .XX° ± 1° | DeFang_Hu 07/22'12 | | DWG NO. | | |
| CUSTOMER DRAWING | | CHECKED BY | | GAP-ADDR0005 | | |
| DRAWN BY | | JinKe_Hu 07/22'12 | | SHEET | | |
| A4 | MM[INCH] | ZhenFeng_Lv 07/22'12 | | 3 / 4 | SCALE | |
| | | | | 5:4 | REV | |
| | | | | C | | |

DETAIL G
Figure 6 Module outline

DETAIL F

DETAIL E

DETAIL D

| REV. | ECN NO./DESCRIPTION | DATE |
|------|---------------------|----------|
| A | R110782 | 01/03'12 |
| B | R110782 | 06/05'12 |
| C | R110782 | 07/22'12 |

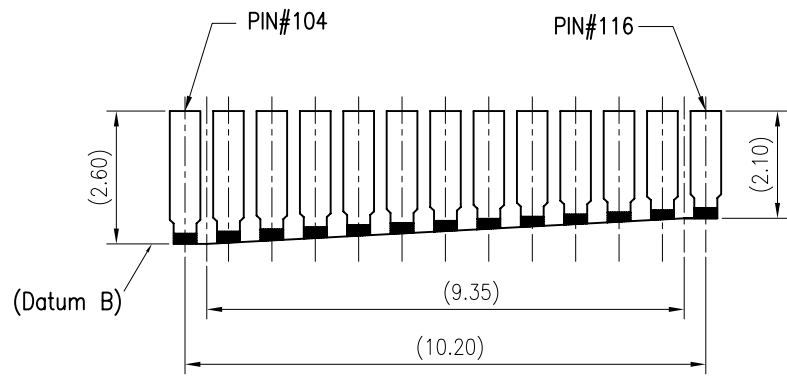
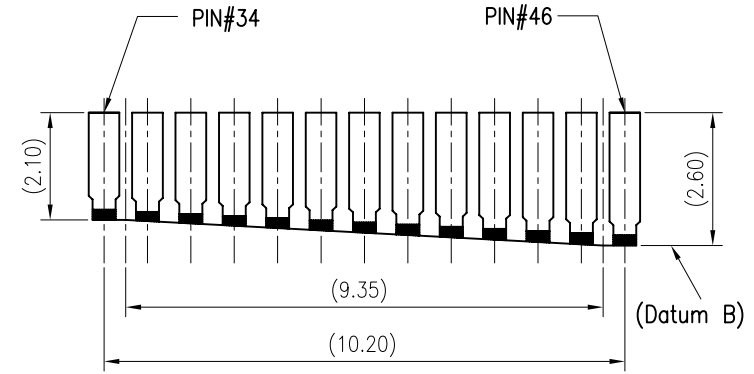
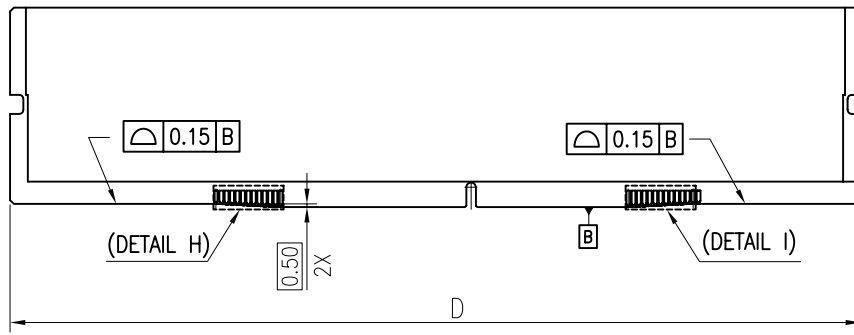
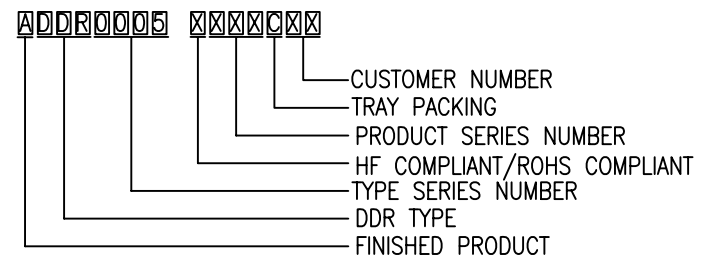

Figure 7 Step and ramp dimensions

6. PRODUCT NUMBER NOTE:



7. TABLE:

| | | | |
|----------------|--|----------------|--------|
| ADDR0005-K014C | PA66+30%GF_BLACK,C7025_30u",MATTE Sn,HOOK;WHITE EJECTOR. | RoHS COMPLIANT | 2.7mm |
| ADDR0005-K013C | PA66+30%GF_BLACK,C7025_15u",MATTE Sn,HOOK;WHITE EJECTOR. | RoHS COMPLIANT | 2.7mm |
| ADDR0005-K012C | PA66+30%GF_BLACK,C7025_G/F,MATTE Sn,HOOK;WHITE EJECTOR. | RoHS COMPLIANT | 2.7mm |
| ADDR0005-K011C | PA46+40%GF_BLACK,C7025_15u"Au,MATTE Sn,HOOK;WHITE EJECTOR. | RoHS COMPLIANT | 2.7mm |
| P/N | SPECIFICATION | REMARK | DIM"A" |

| GENERAL TOLERANCES UNLESS SPECIFIED | | PART NO. | LOTES | | |
|-------------------------------------|-----------|----------------------|-------------------|-------|-----|
| .X ± 0.35 | X° ± 3° | SEE TABLE | | | |
| .XX ± 0.25 | .X° ± 2° | APPROVED BY | TITLE | | |
| .XXX ± 0.15 | .XX° ± 1° | DeFang_Hu 07/22'12 | DDR4 284Pin Conn. | | |
| CUSTOMER DRAWING | | CHECKED BY | DWG NO. | | |
| | | JinKe_Hu 07/22'12 | GAP-ADDR0005 | | |
| SIZE | UNITS | DRAWN BY | SHEET | SCALE | REV |
| A4 | MM[INCH] | ZhenFeng_Lv 07/22'12 | 4 / 4 | 5:4 | C |